

# KA2811C

## 12V Spindle Motor and Voice Coil Motor Driver

### Features

#### SMP Circuit

- 3 phase sensorless BLDC motor driver with speed discriminator
- Built-in start-up circuit with WSS (Waltz step start) method
- Suitable for high and middle end set (Max. output current: 2A)
- Built-in dynamic brake circuit

#### Vcm Circuit

- High output current driver with external NPN & PNP transistors. (Max. output current: 2A)
- No crossover distortion
- Low offset current

#### Other

- Low standby current
- Built-in precision power detector circuit
- Built-in TSD(Thermal Shut Down) circuit

### Description

The KA2811C is a monolithic one-chip IC which includes SPM (Spindle motor) driver, VCM (Voice coil motor) driver and peripheral driver, designed for driving HDD motor. For high starting torque and high speed, SPM circuit employs WSS (Waltz step start) method for starting the motor and can drive up to 2A. VCM circuit is designed to drive up to 1.5A to meet the trends of HDD'S high speed. (Requires external transistors).



### Typical Applications

- Hard disk drive(HDD)

### Ordering Information

Device	Package	Operating Temperature
KA2811C	48-QFPH-1414	0 ~ 70°C

# Pin Assignments

48QFPH (48Quad Flat Package Heat-sink)

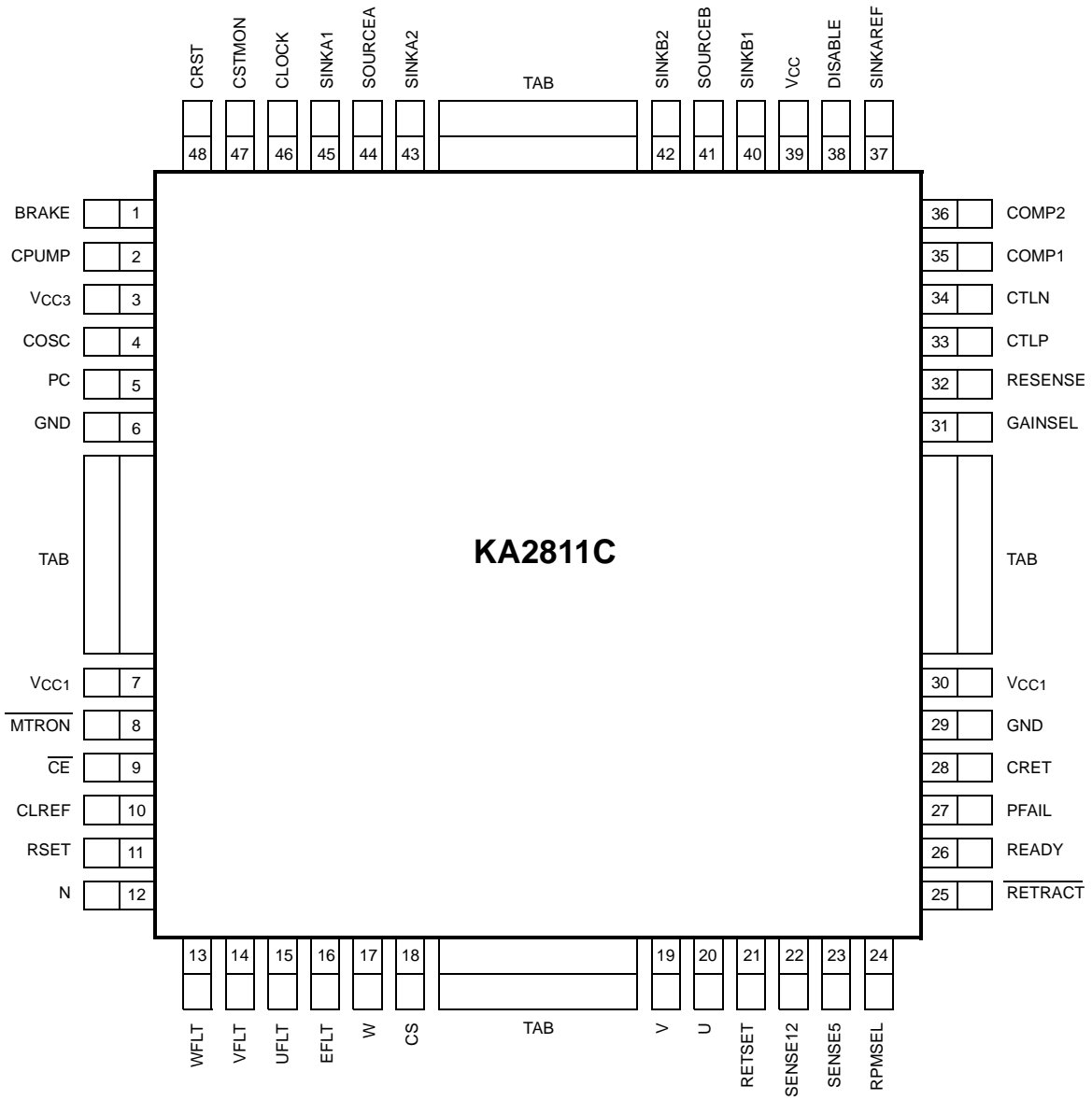

## Pin Definitions

Pin Number	Pin Name	I/O	Pine Function Description
1	BRAKE	O	Brake output
2	CPUMP	-	Charge pump capacitor
3	VCC3(VDD)	-	5V power supply
4	COSC	-	Start-up OSC capacitor
5	PC	-	Phase compensation capacitor
6	GND	-	Ground
7	VCC1	-	12V power supply
8	MTRON	I	Motor on & off control input
9	CE	I	Chip enable (Active low)
10	CLREF	I	Current limit reference voltage
11	RSET	I	Current & voltage setting resistor
12	N	I	Neutral
13	WFLT	I	Input filter of W-phase signal
14	VFLT	I	Input filter of V-phase signal
15	UFLT	I	Input filter of U-phase signal
16	EFLT	I	Back EMF output filter
17	W	O	W-phase output
18	CS	I	Current sensing resistor
19	V	O	V-phase output
20	U	O	U-phase output
21	RETSET	I	Retract voltage setting resistor
22	SENSE12	I	VCC(12V) power supply sense
23	SEMSE5	I	VCC(5V) power supply sense
24	RPMSEL	I	RPM selection
25	RETRACT	I	Retract circuit control input
26	READY	O	Target RPM locking output signal
27	PFAIL	O	Power fail output
28	CRET	I	Retract power charging capacitor
29	GND	-	Ground
30	VCC1	-	12V power supply
31	GAINSEL	I	VCM gain setting (High, Low)
32	RSENSE	I	Current sensing resistor

**Pin Definitions (Continued)**

Pin Number	Pin Name	I/O	Pin Function Description
33	CTLP	I	VCM amp positive input
34	CTLN	I	VCM amp negative input
35	COMP1	I	Compensation capacitor
36	COMP2	I	Compensation capacitor
37	SINKAREF	I	Kelvin sensing point for VCM amp
38	DISABLE	I	VCM part disable
39	VCC2	-	VCM part power supply (12V)
40	SINKB1	I	External NPN-PNP transistor collector
41	SOURCEB	O	External PNP transistor base
42	SINKB2	O	External NPN transistor base
43	SINKA2	O	External NPN transistor base
44	SOURCEA	O	External PNP transistor base
45	SINKA1	I	External NPN-PNP transistor base
46	CLOCK	I	Reference clock input
47	CSTMON	-	Start-up monitoring
48	CRST	-	VCM amp gain adjustable resistor

# Internal Block Diagram

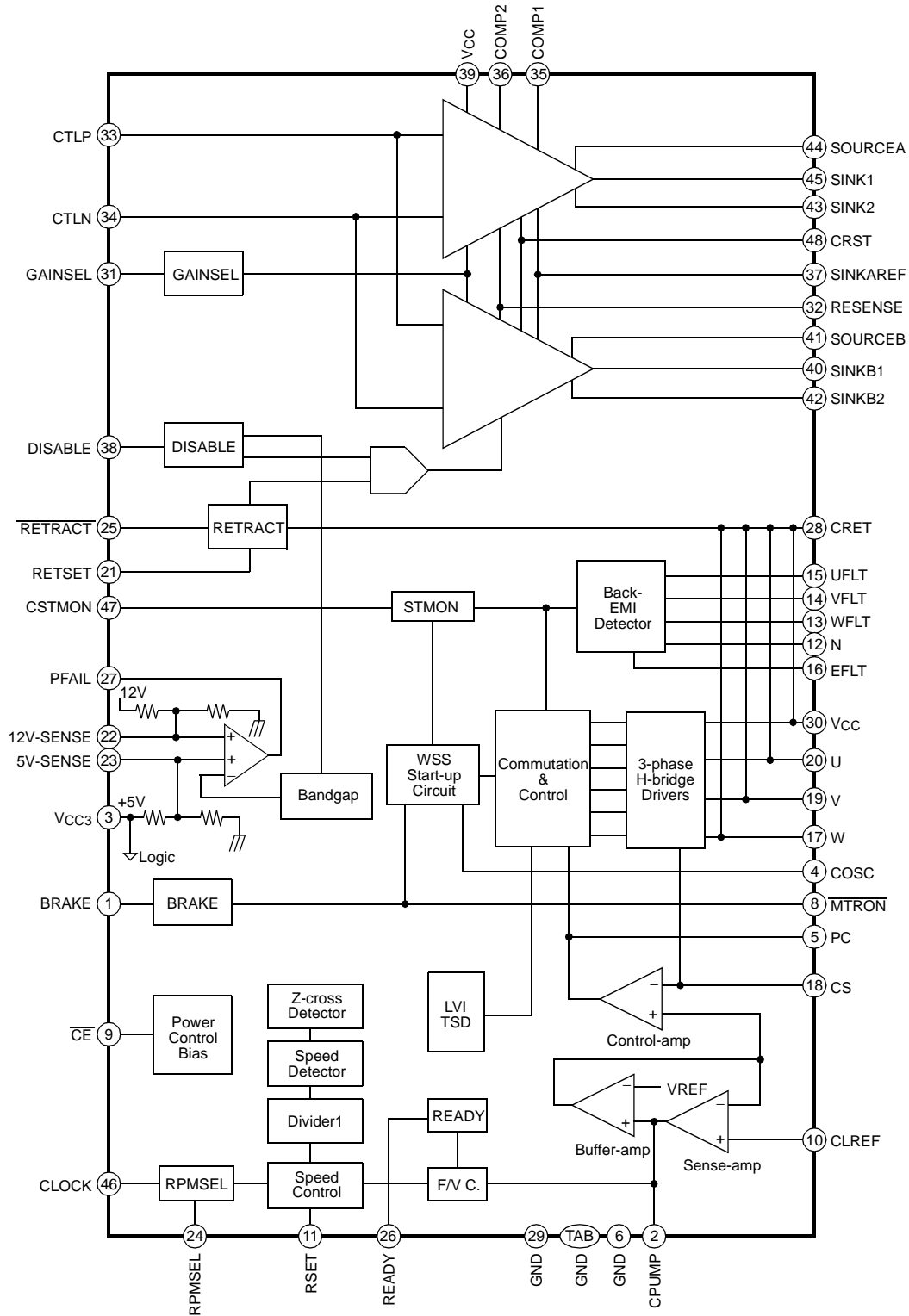

# Equivalent Circuits

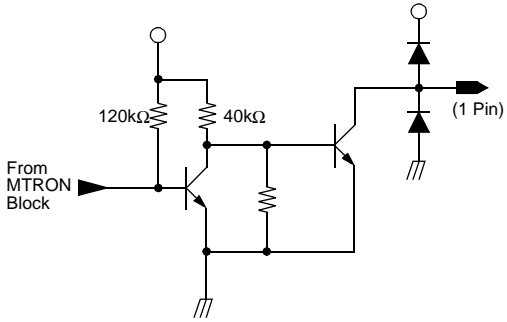
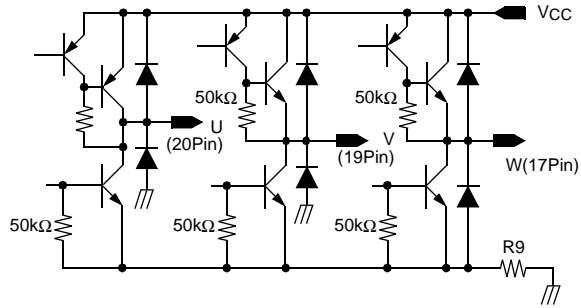
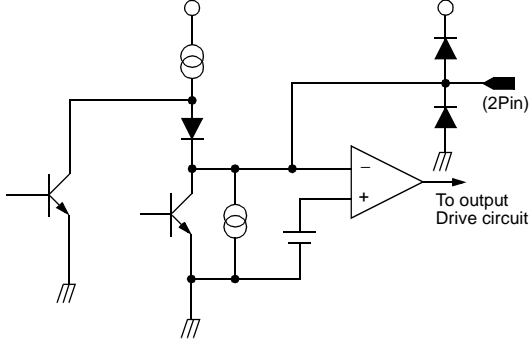
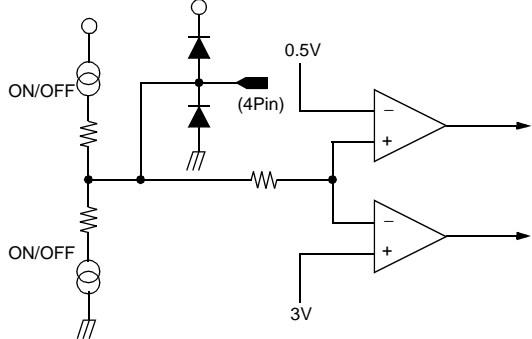
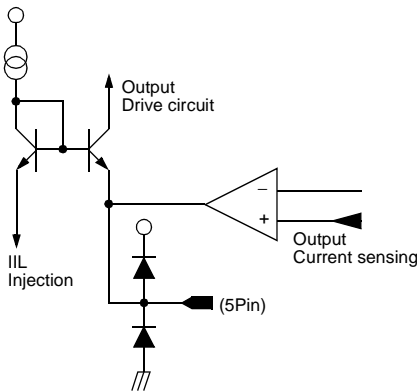
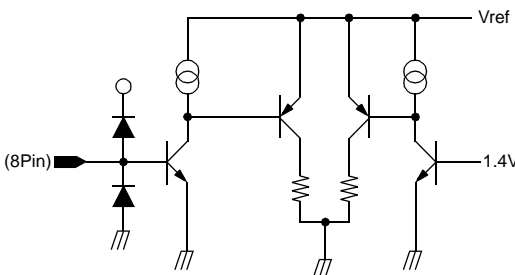
<p style="text-align: center;"><b>Brake output</b></p> 	<p style="text-align: center;"><b>U, V, W drive output</b></p> 
<p style="text-align: center;"><b>Cpump</b></p> 	<p style="text-align: center;"><b>Cosc</b></p> 
<p style="text-align: center;"><b>Pc</b></p> 	<p style="text-align: center;"><b>Mtron</b></p> 

## Equivalent Circuits (Continued)

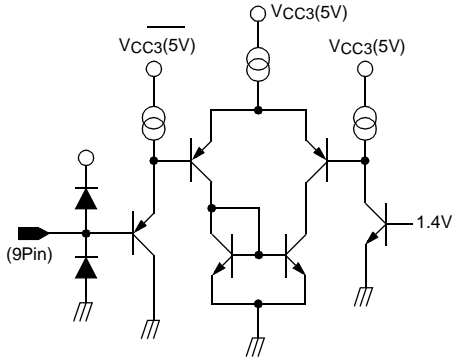
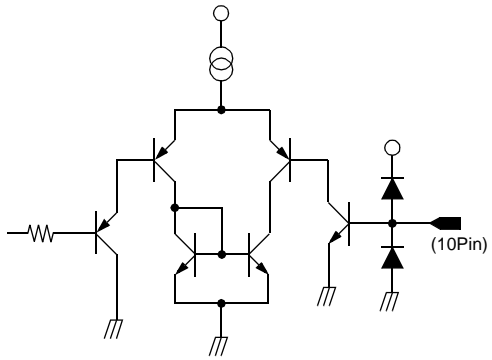
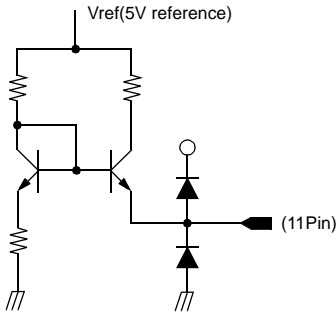
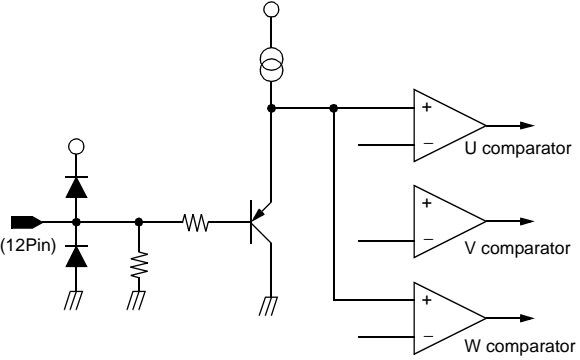
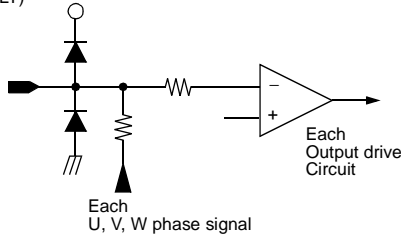
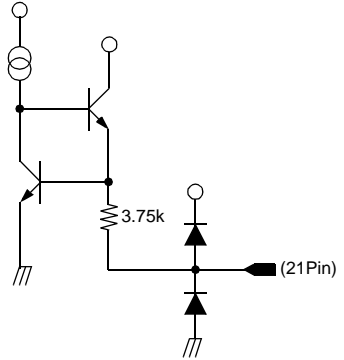
CE input	Clref
	
Rset	N
	
Uflt, Vflt, Wflt	Reset
<p>(15Pin: UFLT) (14Pin: VFLT) (13Pin: WFLT)</p>  <p>Each Output drive Circuit</p> <p>Each U, V, W phase signal</p>	

## Equivalent Circuits (Continued)

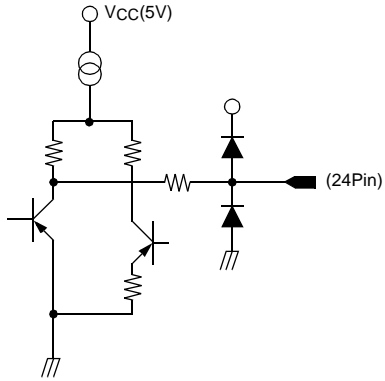
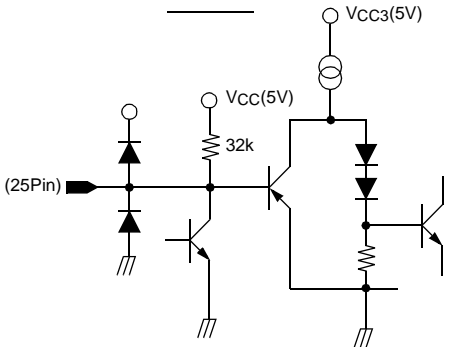
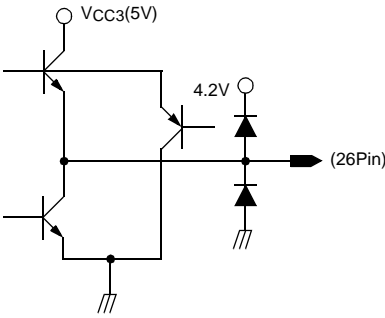
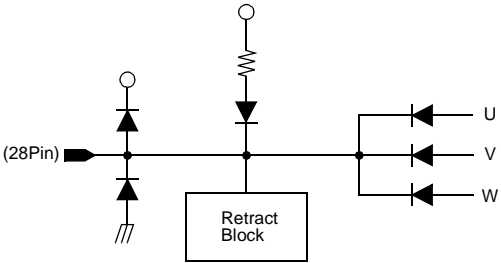
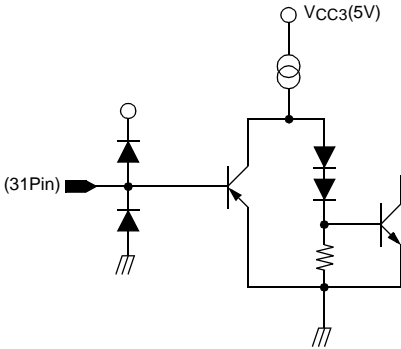
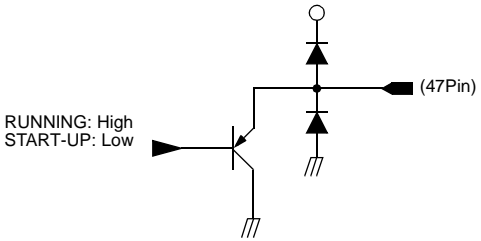
Rpmsel	Retract
	
Ready	Cret
	
Gainsel	Cstmon
	



## Absolute Maximum Ratings (Ta = 25°C)

Parameter	Symbol	Value	Unit
Maximum supply voltage	VCC1MAX, VCC1MAX	15.0	V
Maximum logic part supply voltage 2	VCC3MAX (VDD)	7.0	V
Power dissipation	PD	3.0	W
Maximum output drive current	IOMAX	2.0	A
Logic control input voltage	VIN	-3.0 ~ VCC3	V
Operating temperature range	TOPR	0 ~ 70	°C
Soldering temperature (5 seconds, 1/4 inch from pin)	TSOLD	300	°C
Storage temperature range	TSTG	-55 ~ 150	°C

### Notes:

- Absolute maximum ratings are values beyond which the device may be damaged permanently. Normal operation is not guaranteed at or above those extremes.
- All voltages are measured with respect to the GND voltage level unless otherwise specified.
- When mounted on 50mm × 50mm × 1mm PCB (Phenolic resin material).
- Do not exceed Pd and SOA(Safe Operation Area).

## Power Dissipation Curve

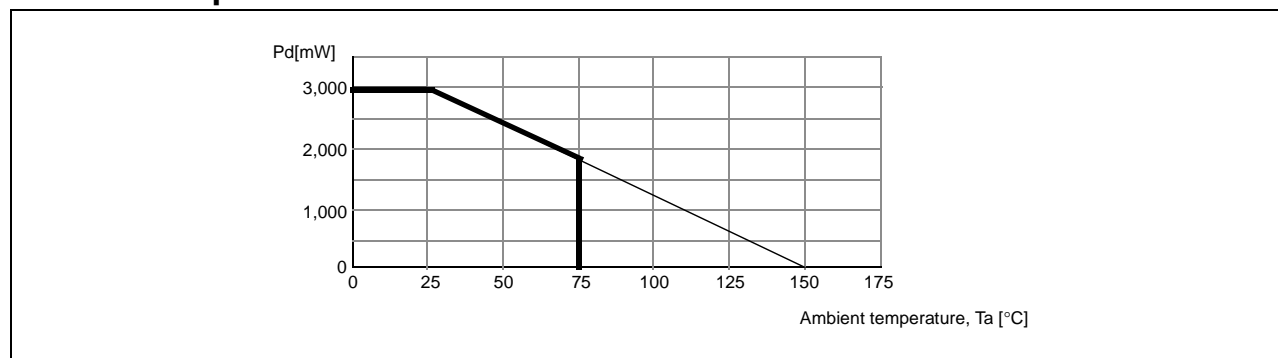

## Recommended Operating Conditions (Ta = 25°C)

Parameter	Symbol	Min.	Typ.	Max.	Unit
Operating supply voltage	VCC1, VCC2	10.8	12.0	13.2	V
Operating supply voltage in logic part	VCC3	4.5	5.0	5.5	V
Ambient operating temperature range	Ta	0	-	+70	°C

## Electrical Characteristics

(Ta=25°C, VCC1, VCC2=12V, VCC3=5V)

Parameter	Symbol	Conditions	Min.	Typ.	Max.	Unit
Quiescent current	ICC2	$\overline{CE}=0V$ , DISABLE=0V	9	14	19	mA
	ICC3	$\overline{CE}=5V$ , DISABLE=5V	2	4.5	7	mA
<b>SPM DRIVE</b>						
CE input threshold voltage	VCETH	-	0.8	-	2.0	V
CE input high current	ICEIH	CE=5V	-	-	±100	μA
CE input low current	ICEIL	CE=0V	-	-	±100	μA
MTRON input threshold voltage	VMOTH	-	0.8	-	2.0	V
MTRON input high current	IMIHI	MTRON=5V	-	-	±100	μA
MTRON input low current	IMILI	MTRON=0V	-	-	±100	μA
Start-up oscillation high threshold voltage	VSTTHH	CEXT=0.068μF	2.6	3.0	3.4	V
Start-up oscillation low threshold voltage	VSTTHL	CEXT=0.068μF	0.3	0.5	0.7	V
Start-up oscillation frequency	FST	CEXT=0.068μF	100	145	190	Hz
Start-up oscillation high frequency charging current	IHFCHA	CSTMON=0V	-68	-52	-36	mA
Start-up oscillation high frequency discharging current	IHFDCI	CSTMON=0V	32	48	64	μA
Start-up oscillation low frequency charging current	ILOFCHA	CSTMON=5V	-	-1.5	-8	μA
Start-up oscillation low frequency discharging current	ILOFDCI	CSTMON=5V	36	48	64	μA
Start-up monitor low voltage	VSML	IO=1mA	-	1	0.4	V
Start-up monitor switching voltage	VSTART	-	2.0	2.5	3.0	V
Charge pump R1 setup voltage	VCP	R1=10kΩ	0.85	1.0	1.15	V
Charge pump discharge current	ICPDCH	-	20	50	80	μA
Charge pump charging current	ICPCHA	-	-65	-50	-35	μA
Charge pump leakage current	ICPLKG	-	-	-	±1	μA
Ready output high voltage	VR1	IO=-1.0mA, UFLT=300Hz	3.6	4.2	4.8	V
Ready output high voltage	VR2	IO=-1.0mA, UFLT=360Hz	3.6	4.2	4.8	V
Ready output low voltage	VREADY	-	-	-	0.4	V

## Electrical Characteristics (Continued)

(Ta=25°C, VCC1, VCC2=12V, VCC3=5V)

Parameter	Symbol	Conditions	Min.	Typ.	Max.	Unit
Output leakage current 1	ILKG	VCC=12.0V (Up U)	-	-	±200	μA
	ILEA2	VCC=12.0V (Up V)	-	-	±200	μA
	ILEA3	VCC=12.0V (Up W)	-	-	±200	μA
	ILEA11	VCC=12.0V (Low U)	-	-	±200	μA
	ILEA12	VCC=12.0V (Low V)	-	-	±200	μA
	ILEA13	VCC=12.0V (Low W)	-	-	±200	μA
Output saturation voltage	VSAT (U, V, W)	IO=100mA	-	-	0.8	V
		IO=300mA	-	-	1.2	V
		IO=500mA	-	-	1.5	V
		IO=1A	-	-	2.0	V
		IO=1.5mA	-	-	3.0	V
RPMSEL input low current	IRPML	RPMSEL=0V	-80	-45	-10	μA
RPMSEL input high current	IRPMH	RPMSEL=5V	10	40	70	μA
Brake output low voltage	VBRK	IO=0.5mA	-	-	0.4	V
Low voltage inhibit	VLVI	-	6	-	8	V
<b>VCM DRIVE</b>						
Offset current	IOFF	RSENSE=1Ω	-9	-	9	mA
1/4 gain	G1/4	GAINSEL=2V	227	250	278	mA/V
1/16 gain	G1/16	GAINSEL=0.8V	53	63	73	mA/V
Sinking saturation 11 voltage	VNSAT11	IO=100mA	-	0.3	-	V
Sinking saturation 12 voltage	VNSAT12	IO=300mA	-	0.4	-	V
Sinking saturation 13 voltage	VNSAT13	IO=500mA	-	0.5	-	V
Sinking saturation 21 voltage	VNSAT21	IO=100mA	-	0.3	-	V
Sinking saturation 22 voltage	VNSAT22	IO=300mA	-	0.4	-	V
Sinking saturation 23 voltage	VNSAT23	IO=500mA	-	0.5	-	V
Sourcing saturation 11 voltage	VPSAT11	IO=100mA	-	0.3	-	V
Sourcing saturation 12 voltage	VPSAT12	IO=300mA	-	0.4	-	V
Sourcing saturation 13 voltage	VPSAT13	IO=500mA	-	0.5	-	V
Sourcing saturation 21 voltage	VPSAT21	IO=100mA	-	0.3	-	V
Sourcing saturation 22 voltage	VPSAT22	IO=300mA	-	0.4	-	V
Sourcing saturation 23 voltage	VPSAT23	IO=500mA	-	0.5	-	V
SOURCEA base drive current	ISOAB	-	20	-	-	mA
SOURCEB base drive current	ISOBB	-	20	-	-	mA

## Electrical Characteristics (Continued)

(Ta=25°C, VCC1, VCC2=12V, VCC3=5V)

Parameter	Symbol	Conditions	Min.	Typ.	Max.	Unit
SINK2 base drive current	ISIAB	-	20	-	-	mA
SINKB2 base dirve current	ISIBB	-	20	-	-	mA
RESET voltage	VRESET	-	0.5	0.75	0.95	V
SOURCE voltage	VSRC	CRET=3V	1.0	1.6	2.2	V
SINK current	ISIN	SINKB1=0.5V	36	48	60	-
RETRACT output low voltage	VREOUT	ISINKB1=1mA	-	-	0.4	mA
12V threshold voltage	VTH2	-	9.0	10	11	V
12V hysteresis voltage	VHYS12	-	-	150	-	mV
5V threshold voltage	VTH5	-	1.2	4.6	4.85	V
5V hysteresis voltage	VHYS5	-	-	75	-	mV
Power fail output low voltage	VOPF	-	-	-	0.4	V
GAINSEL high input voltage	VIHGAIN	-	2.0	-	-	V
DISABLE high input voltage	VIHDIS	-	2.0	-	-	V
RETRACT high input voltage	VIHRET	-	2.0	-	-	V
GAINSEL low input voltage	VILGAIN	-	-	-	0.8	V
DISABLE low input voltage	VILDIS	-	-	-	0.8	V
RETRACT low input voltage	VILRET	-	-	-	0.8	V
DISABLE high input current	IiHDIS	VIN=5V	-	10	40	μA
GAINSEL high input current	IiHGAIN	VIN=5V	-	-	±10	μA
RETRACT high input current	IiHRET	VIN=5V	-	-	±10	μA
DISABLE low input current	IiLDIS	VIN=0V	-	-	±10	μA
GAINSEL low input current	IiLGAIN	VIN=0V	-40	-10	-	μA
RETRACT low input current	IiLRET	VIN=0V	-250	-160	-	μA

## Application Information

### 1. SPINDLE MOTOR CIRCUIT

#### 1. Bias

The circuit biases the spindle block and is configured of a bandgap circuit as illustrated in figure 1 below.

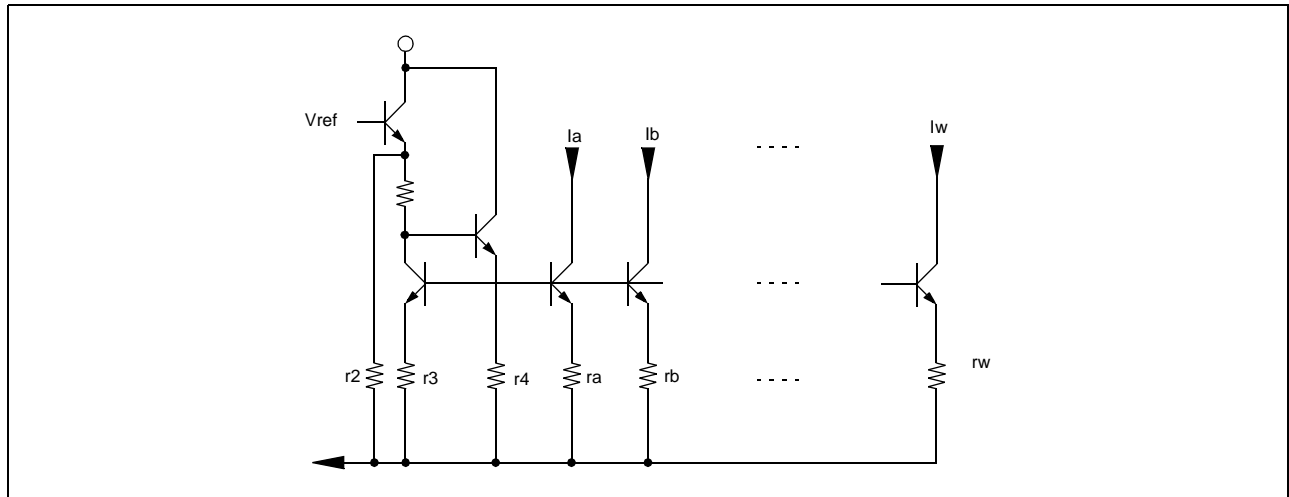

Figure 1. Bias block internal circuit

Where  $r3 = ra = rb \dots\dots\dots = rw$ .

Pin no.9 (CE) is capable to enable or disable the spindle block.

#### 2. Start-up

This concerns initial drive of the spindle motor. The Waltz Step start (WSS) method has been applied to obtain high torque.

The WSS starts the 3-phase spindle motor in 3 steps just like a waltzing rhythm not in 4 step as shown below.



The start-up is effected by driving output stage of the block with the sliding COSC clock and setting the signals of CE and MTRON at the low state (See the start-up timing chart).

When the spindle motor is in start-up mode, the voltage at pin 47 should measure 1.4V and in the running mode 2.5V. The equations below represent the timing of each mode.

Transition time from start-up high frequency to low frequency:

$$V_{\text{pin no. 47}} (\cong 1.4V) = 5V \times \left(1 - e^{-\frac{t}{\tau}}\right)$$

$$t = \tau \ln (3.6/5)$$

Delay time from the start-up start-up to running modes:

$$V_{\text{pin no. 47}} (\cong 2.5V) = 5V \times \left(1 - e^{-\frac{t}{\tau}}\right)$$

$$t = -\tau \ln 0.5$$

### 3. BEMF detector

This circuit detects the signals to CE and MTRON to determine BEMF (Back Electromotive force) level required to maintain self-commutation of the spindle motor. The block is configured of BEMF amplifier and voltage detector circuits.

### 4. Zero cross detector

This circuit controls the rotating speed of the spindle motor with the output obtained from the comparator which compares the U phase voltage (among U, V, W phase voltages that are the actual elements of BEMF of the motor) with the neutral voltage of the motor.

### 5. RPM selector

The selection mode at the pin no. 24 and the clock at the Pin no. 48 enables to run the motor at specific RPM within the range of 3600/4500/5400 as follows

Pin no. 24 (RPMSEL)	Pin no. 46 (CLOCK)	Target RPM	Remark
Low (0V)	4MHz	3600	-
	5MHz	4500	-
	6MHz	5400	-
High (5V)	5MHz	5400	-
Open	-	-	Not use

### 6. Speed control circuit

It compares input reference clock with the output phase of zero cross over detector which is proportional to motor speed by means of PLL (Phase lock loop) circuit.

After that, it provides the data of speed error to the F/V block as pulse.

### 1-1. RPM of Motor

$$N_O = \frac{f_{ck} \times 60 \times D1}{N_{cnt} \times P_O \times D2}$$

Here,

$N_O$  = RPM

$f_{ck}$  = Reference clock (Pin no. 46),

$D1$  = Divided clock ratio,

$D2$  = Divided zero cross signal ratio,

$P_O$  = Motor pair pole (8 pole motor:  $P_O = 4$ )

$N_{cnt}$  = PLL counted value

Pin 24 = 0V →  $N_{cnt} = 2084$

Pin 24 = 5V →  $N_{cnt} = 1736$

ex)

$f_{ck} = 5\text{MHz}$ , Pin no. 24 = 5V, Mode ( $N_{cnt} = 1736$ )

$$N_O = \frac{f_{ck}}{N_{cnt}} \times 1.875 = 5400.346\text{rpm} \cong 5400\text{rpm}$$

### 1-2. Speed error (%)

$$\begin{aligned} \text{RPMerror} &= \frac{I_{\text{HOLD}}}{N_{cnt}} \times 100 \\ &= I_{\text{HOLD}} \times (R10 + R11) \times 100 \end{aligned}$$

Here,  $I_{\text{HOLD}}$  = Leakage current (Pin no. 2)

ex) At the KA2811C

$$\text{RPMerror} = 100\mu\text{A} \times 10\text{k}\Omega \times 100 = 0.1\%$$

### 7. F/V converter

This circuit converts the digital output signals from the speed control block into DC voltage and then feeds the voltages to buffer amplifier.

### 8. Control amp

It compensates the total gain and phase of SPM circuit.

It operates sense amp during start-up, and incorporates output voltage and feedback loop by F/V input during running.

### 9. Sense amp

It determines maximum output current during the start-up.

### 10. Ready

It generates high Ready output when motor speed reaches target RPM.

### 11. Brake

While the spindle motor is in rotation at the target RPM. the signal voltage at the pin 1 sets to the low state that the brake function is not activated.

If however, the power is turned off or the chip is disabled, the internal circuit of the pin 1 will be opened. In this way, the voltage at the capacitor C4 will be discharged through the resistor R4 and triggers the dual MOSFET turned on.

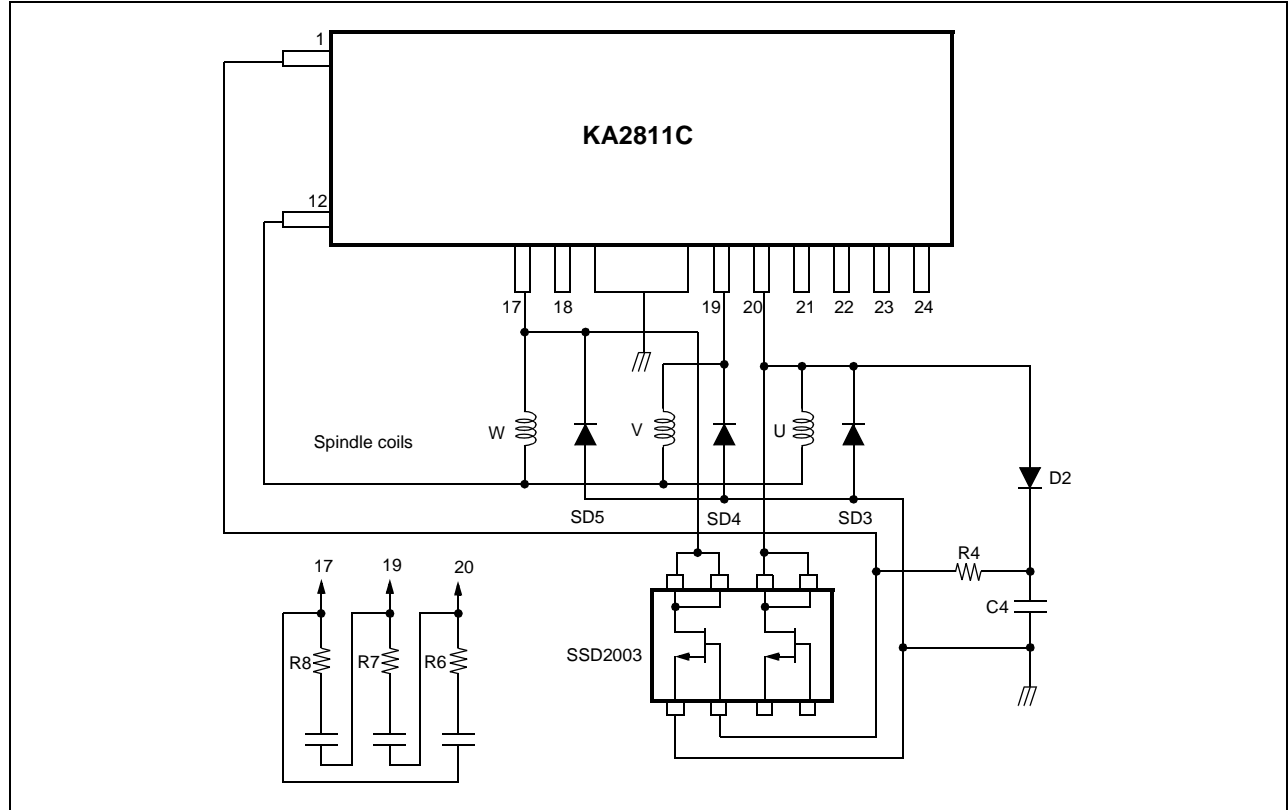

Figure 2. Brake circuit

12. Protector

UVLO (Under voltage lockout)

The protector shuts down internal bias by the function of UVLO when the power supply voltage drops below 6V (min).

TSD (Thermal shutdown)

It shuts down the driver in case the chip temperature should rise upto 150°C by the function of thermal shutdown (TSD) circuitry.



## 2. VCM CIRCUIT

### 1. Current Amplifier

Current amplifier is capable of gain adjustment with use of six external resistors.

The design is implemented in a configuration that ensures minimum crossover distortion characteristics.

It externally employs dual power transistors of NPN & PNP types of  $I_{max} = 3A$  current rating in order to minimize IC loss and maximize output driving capability.

(Dual NPN: SSD1001, Dual PNP: SSD1002)

### 2. Retract circuit

The power for this circuit is derived from the spindle motor BEMF after having filtered by 3 diodes (self-contained) and the capacitor C3 at the pin 28(CRET).

Retract function is active when the “Low” level is applied to the input (Pin 25) which turns the pin 40 (SINKB1) to “Low” state and sets the bias voltage of pin no. 32 (RSENSE) as expressed below:

$$V_{pin32}[V] = \frac{0.7[V]}{3.75[k\Omega] + R5[k\Omega]} \times 3 \times 3.75[k\Omega]$$

VCM current during the retraction is determined by the resistor R5.

### 3. DISABLE Pin

Enables or disables of VCM circuit.

### 4 GAINSEL

This function selects the gain mode.

When the input to pin 31 (GAINSEL) is at high state, it selects high gain mode, and if low, it becomes low gain mode.

#### 2-1. Gain selection method

$$\text{High gain (Pin31 = 5V)} = \frac{R2P + RFP}{R1P}$$

$$\text{Low gain (Pin32 = 0V)} = \frac{RFP}{R1P + R2P}$$

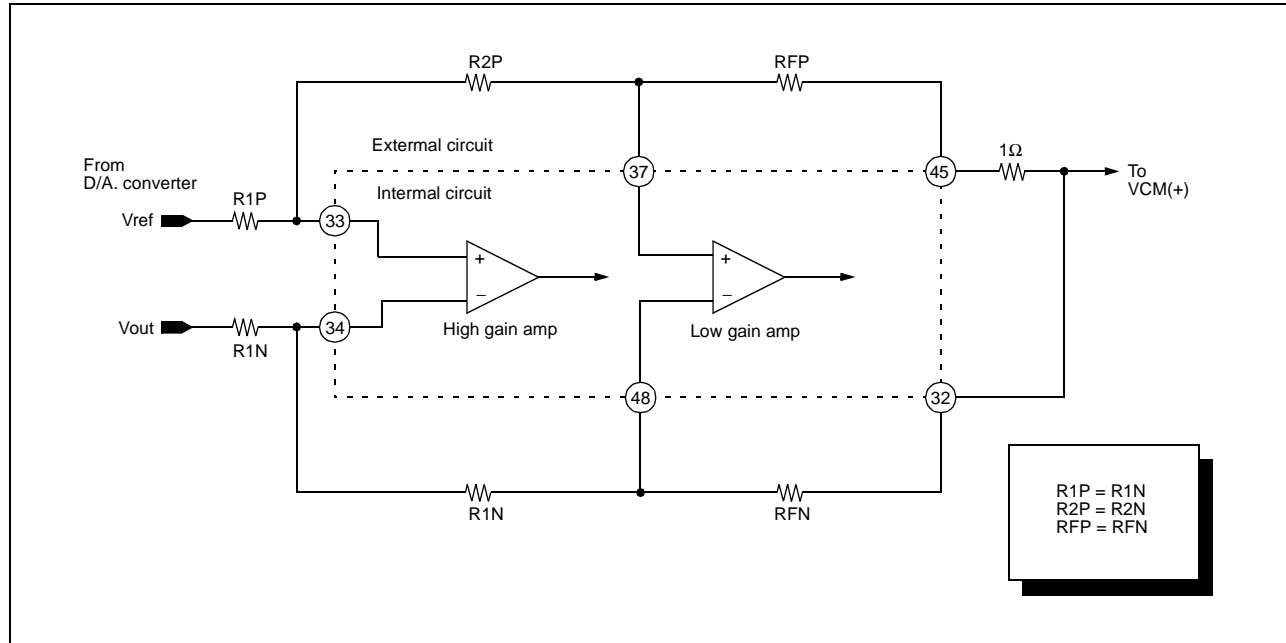

Figure 3. VCM gain amp circuit

## 5. Power Fail Detector

It checks the power of 12V and 5V.

The bandgap reference circuit is used to maintain internal reference voltage.

Assume in Fig.4 that the bandgap reference voltage is 1.5V and the normal voltage level of VCC1 & 2 (12V) or VCC3 (5V) is decreased.

If the voltage at any one pin 22, 23 drops down to 1.5V level, when the comparator output (PFAIL) turns to low from high which is normal running state.

In this example, the voltages of VCC1 & 2 and VCC3 are obtained by the following expressions:

$$\begin{aligned}
 V_{CC1,2} &= V_{\text{pin no. 22}} \times \frac{R1 + R2}{R2} \\
 &= 1.5[\text{V}] \times \frac{12.75[\text{k}\Omega] + 2.25[\text{k}\Omega]}{2.25[\text{k}\Omega]} \\
 &= 9.999[\text{V}] \text{ or less}
 \end{aligned}$$

$$\begin{aligned}
 V_{CC3} &= V_{\text{pin no. 23}} \times \frac{R3 + R4}{R4} \\
 &= 1.5[\text{V}] \times \frac{3.075[\text{k}\Omega] + 1.5[\text{k}\Omega]}{1.5[\text{k}\Omega]} \\
 &= 4.757[\text{V}] \text{ or less}
 \end{aligned}$$

Hysteresis: VCC1, 2 = 90mV (Typ)

VCC3 = 45mV (Typ)

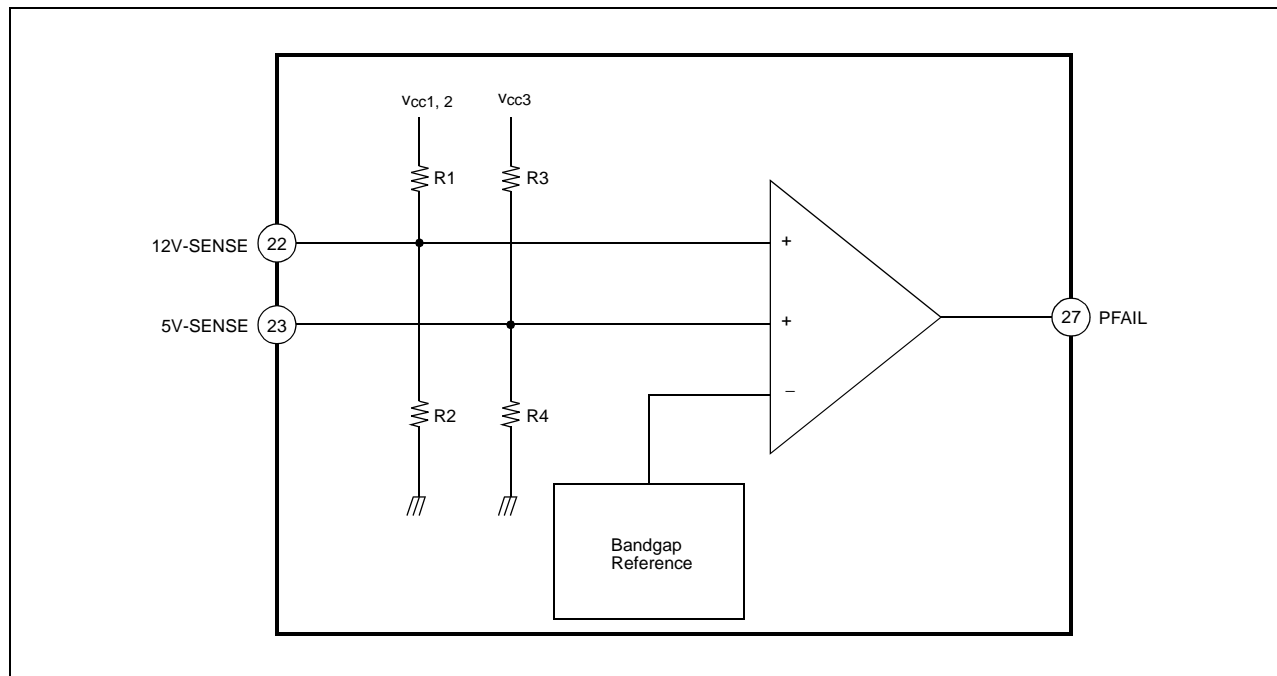
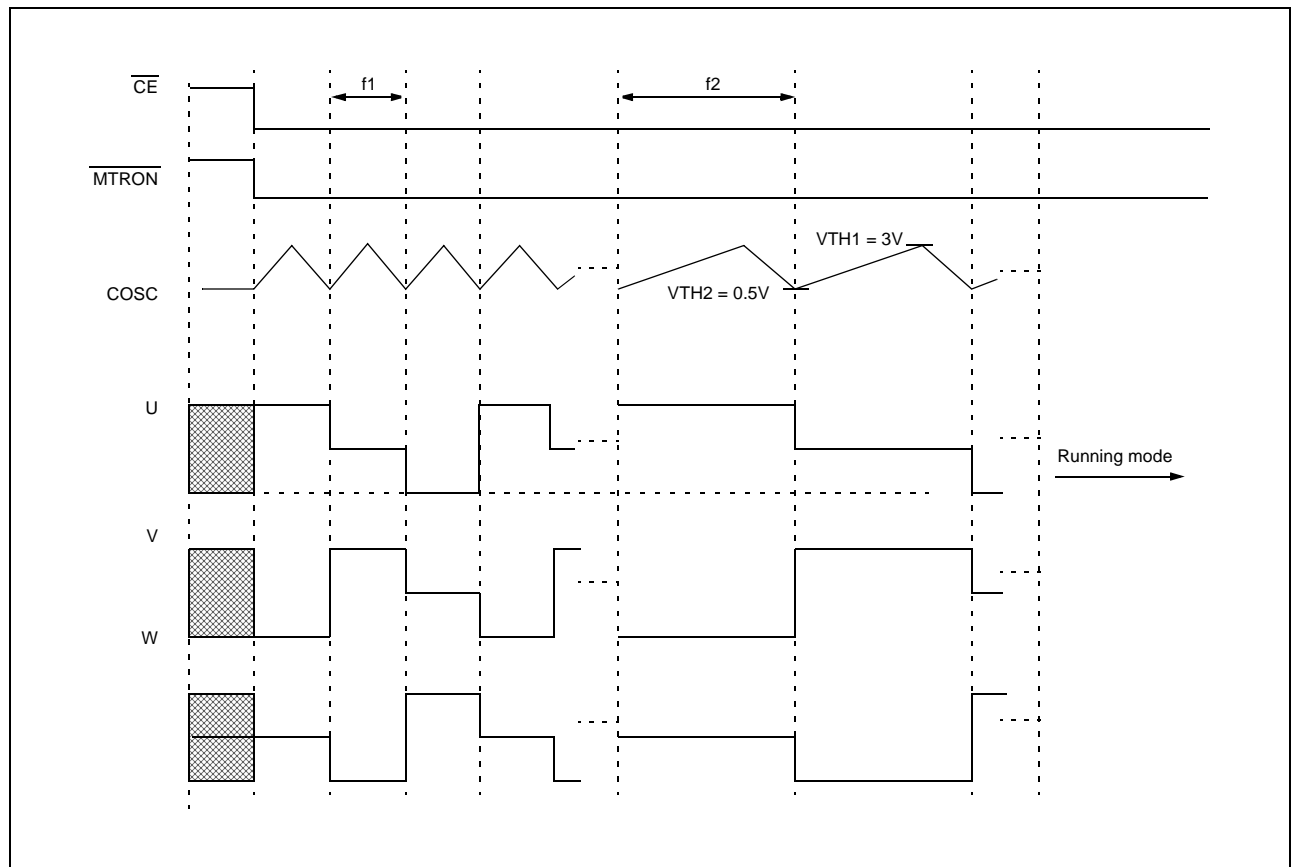

Figure 4. Power fail circuit

# timing chart

## Start-up



**From Start-up Mode To Running Mode Waveform**

6-Nov-96  
14:27:17

**1**  
50 ms  
5.0 V

**3**  
50 ms  
2.00 V

**2**  
50 ms  
2.00 V

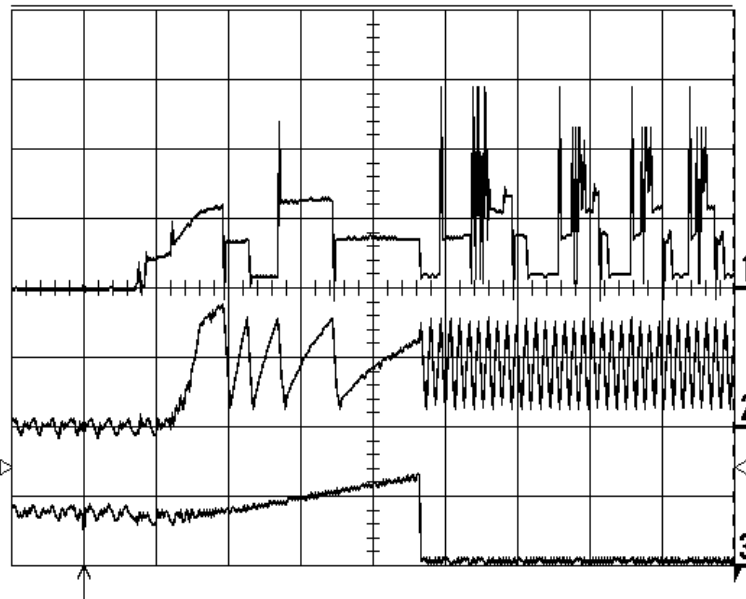

Pin20  
(U Phase)

Pin4(OSC.)

Pin47  
(CSTMON)

maximum(1) 14.53 V  
ampl(1) 10.94 V  
freq(1) - - -

50 ms BWL

**1** .5 V DC  $\times \frac{10}{10}$   
**2** .2 V DC  $\times \frac{10}{10}$   
**3** .2 V DC  $\times \frac{10}{10}$   
**4** .2 V AC

 **3** DC 2.96 V

Synchronous Driving Waveform (Start-up Mode)

6-Nov-96  
13:45:26

1  
.1 s  
5.0 V

2  
.1 s  
2.00 V

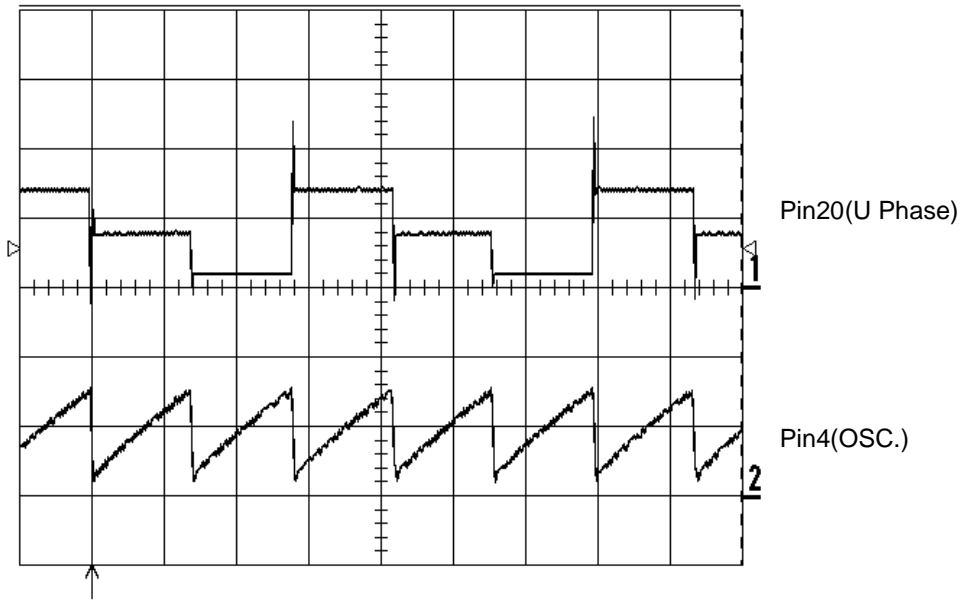

maximum(1) 12.34 V  
ampl(1) 3.12 V  
freq(1)  $\square$  2.400 Hz

.1 s

- 1 .5 V DC  $\times$
- 2 .2 V DC  $\times$
- 3 .2 V AC  $\times$
- 4 .2 V AC

 1 DC 2.9 V

Running Mode Waveform

6-Nov-96  
14:29:16

**1**  
1 ms  
5.0 V

**3**  
1 ms  
5.0 V

**2**  
1 ms  
5.0 V

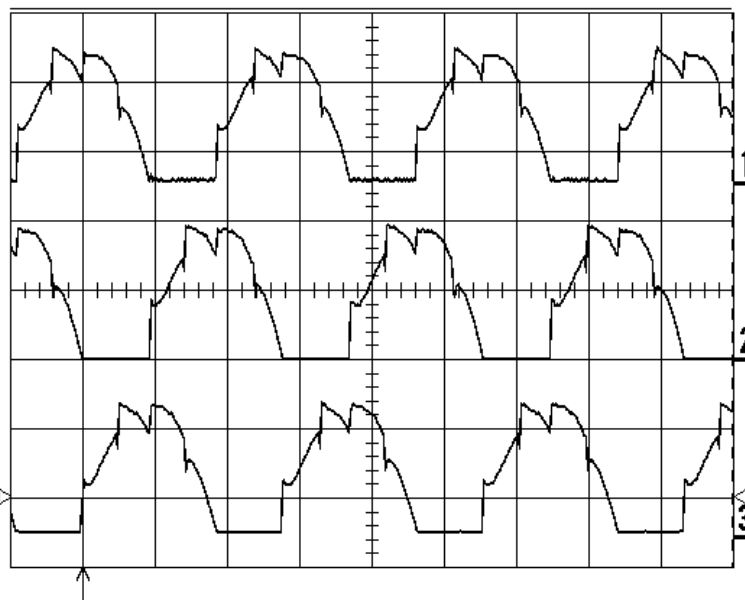

U Phase

V Phase

W Phase

maximum(**1**)      9.91 V  
 ampl(**1**)        8.97 V  
 freq(**1**)      ΠΠ    360.4 Hz

1 ms      BWL

**1** .5 V DC  $\times \frac{10}{10}$   
**2** .5 V DC  $\times \frac{10}{10}$   
**3** .5 V DC  $\times \frac{10}{10}$   
**4** .2 V AC



**3** DC 3.0 V

## Typical Performance Characteristics

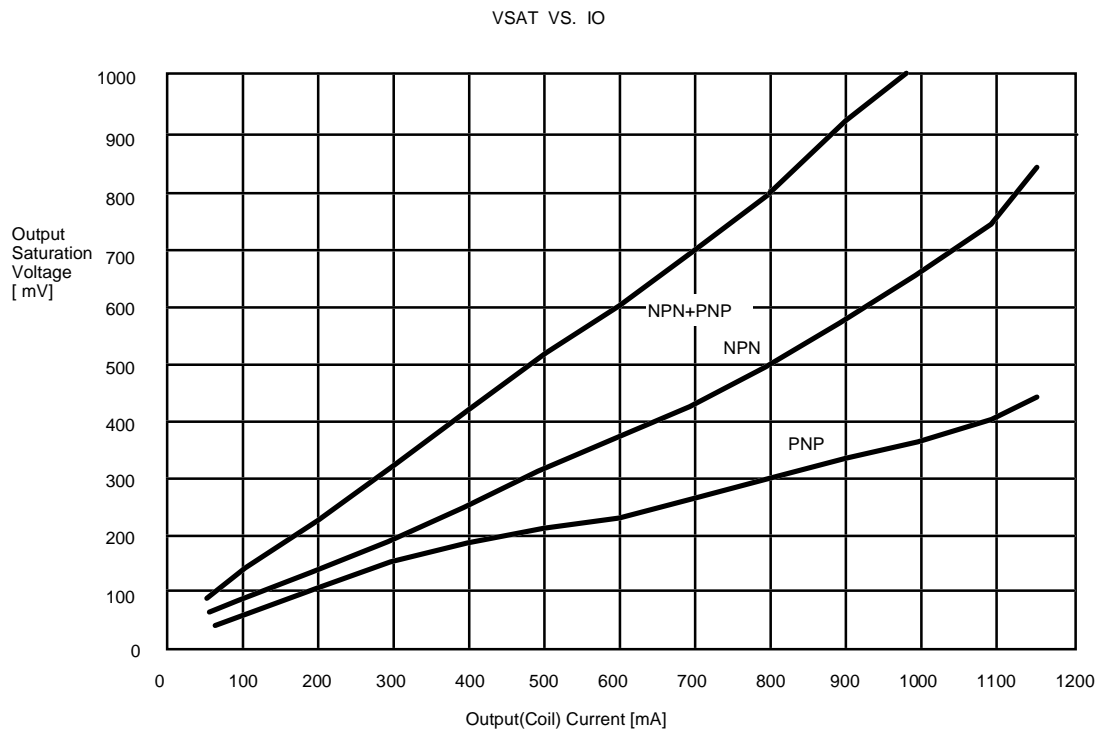

VCM Output Saturation Voltage vs. VCM Output Current  
 ( NPN TRs = SSD1001, PNP TRs =SSD1002 )



## Test Circuits

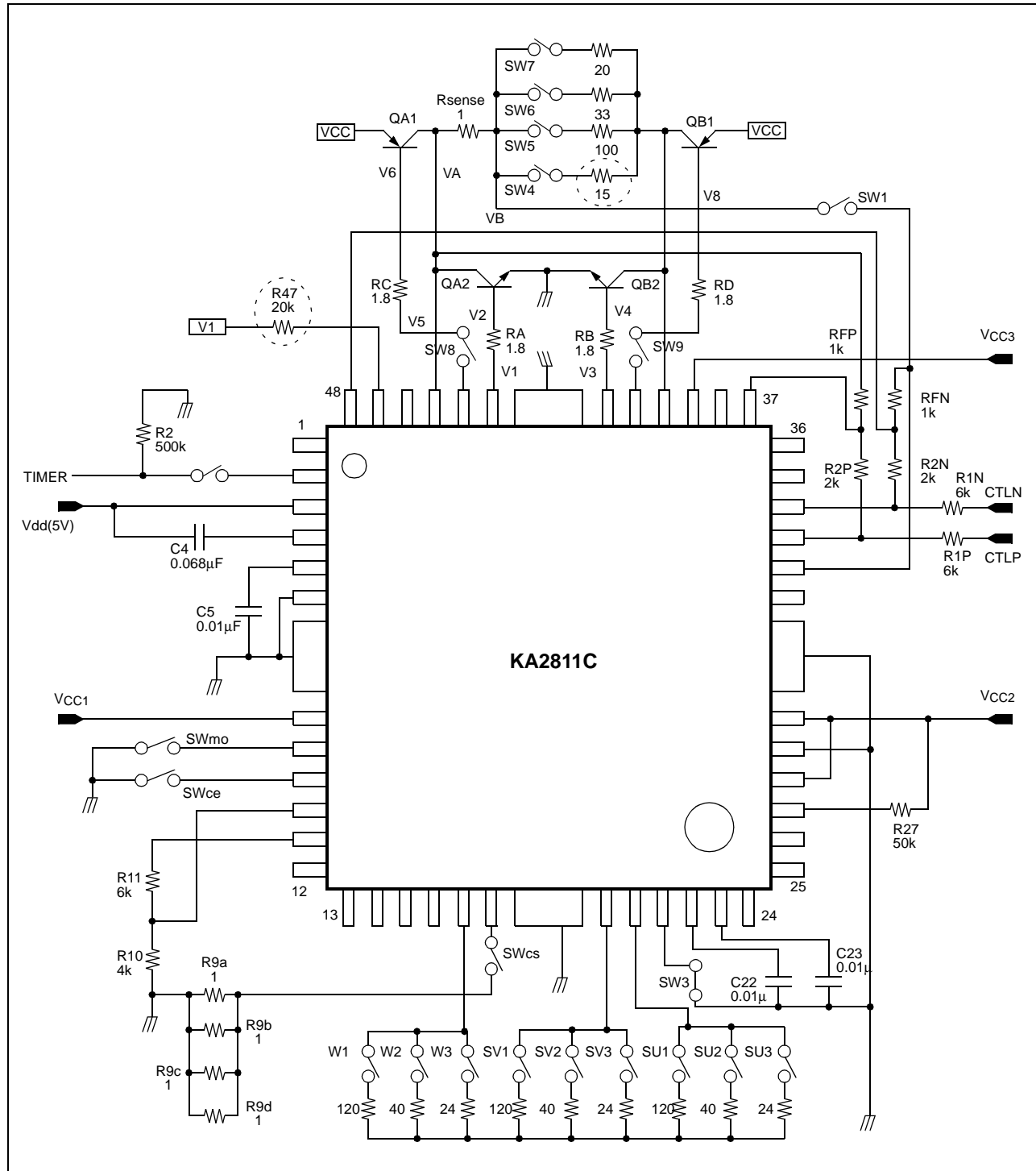

# Typical Application Circuits

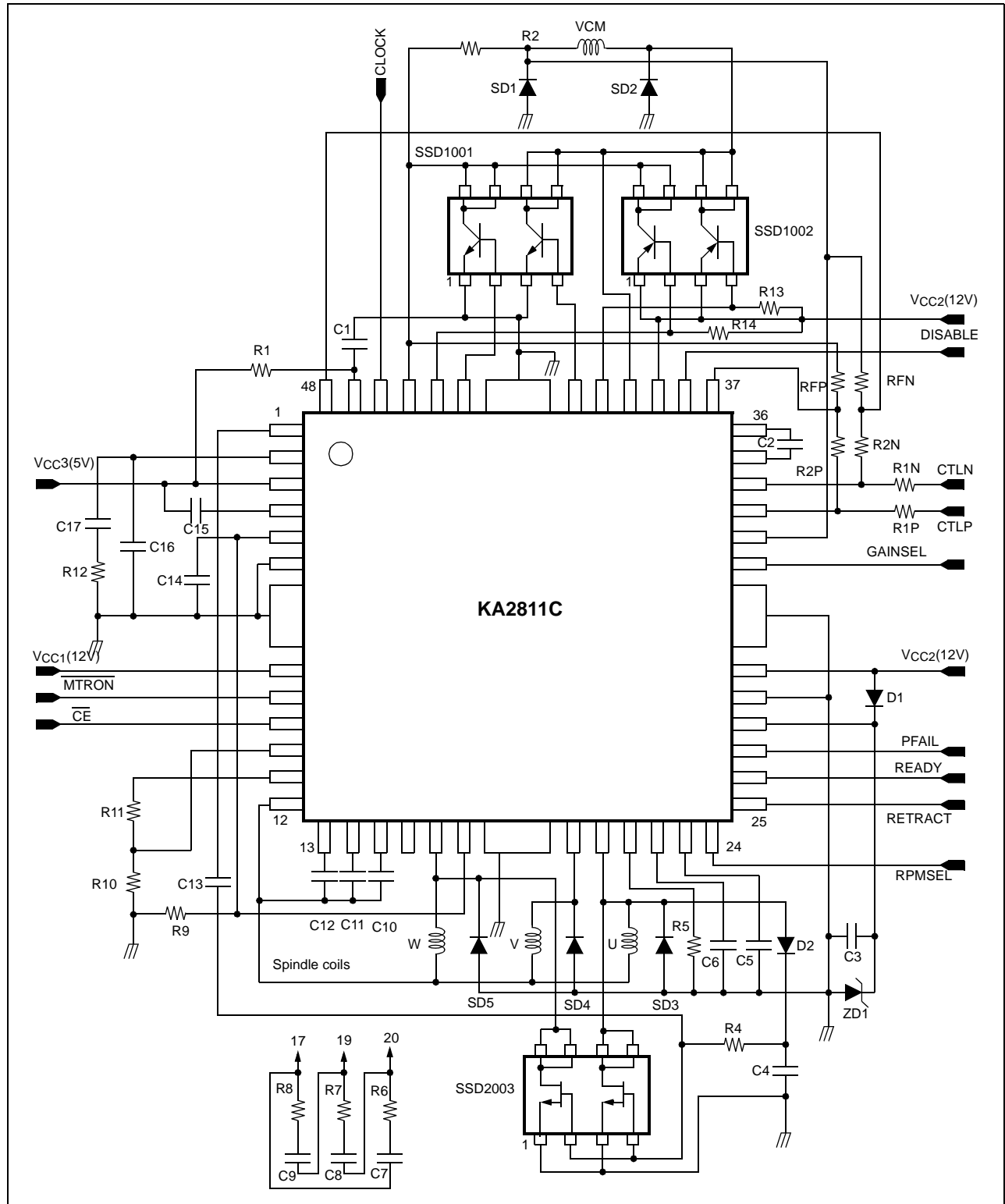

**Notes:**

Break down voltage of ZD1 < maximum supply voltage (15V).

# 48-QFPH-1414

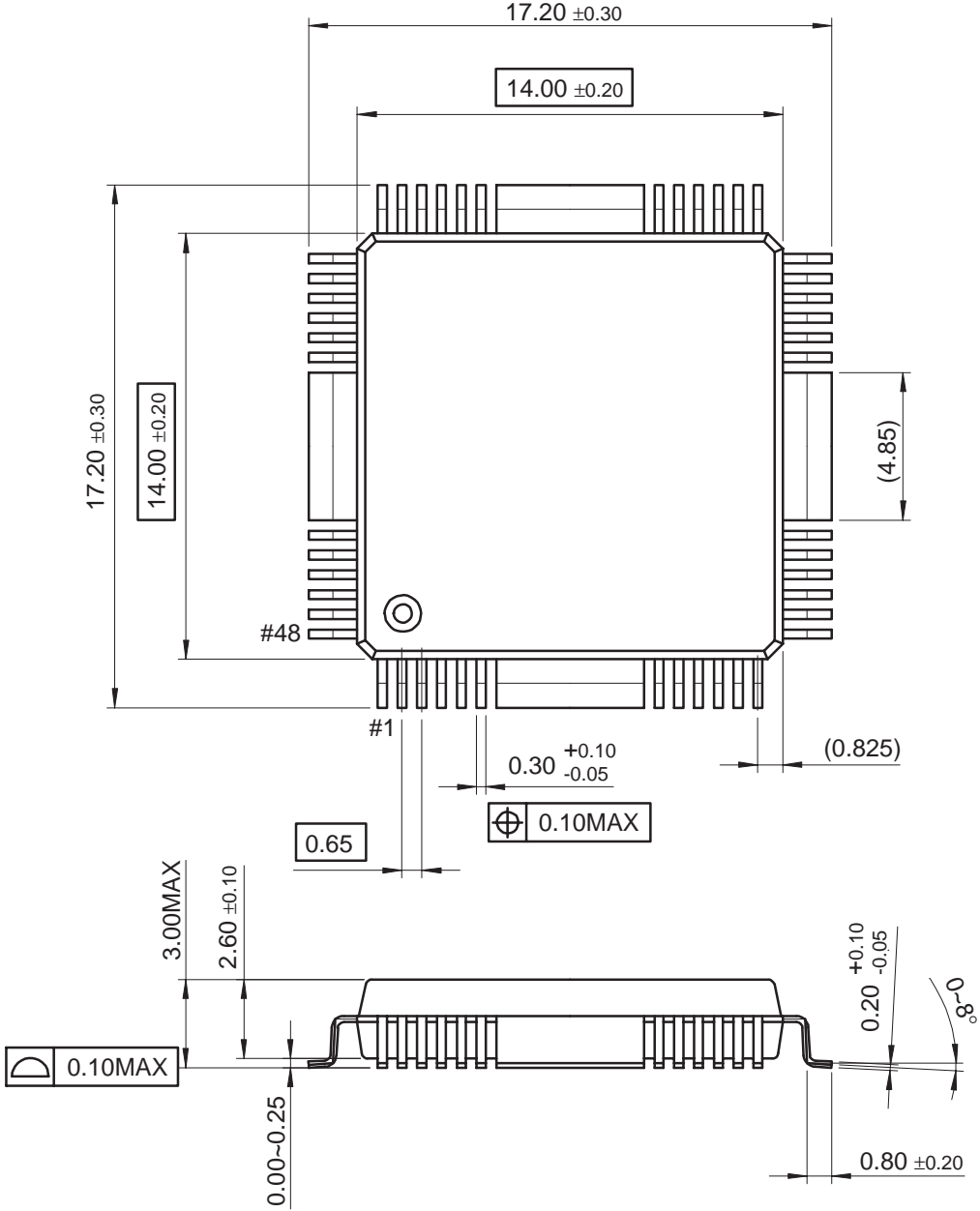

## TRADEMARKS

The following are registered and unregistered trademarks Fairchild Semiconductor owns or is authorized to use and is not intended to be an exhaustive list of all such trademarks.

ACE <sup>x</sup> <sup>TM</sup>	FAST <sup>r</sup> <sup>TM</sup>	QFET <sup>TM</sup>	VCX <sup>TM</sup>
Bottomless <sup>TM</sup>	GlobalOptoisolator <sup>TM</sup>	QS <sup>TM</sup>	
CoolFET <sup>TM</sup>	GTO <sup>TM</sup>	QT Optoelectronics <sup>TM</sup>	
CROSSVOLT <sup>TM</sup>	HiSeC <sup>TM</sup>	Quiet Series <sup>TM</sup>	
DOME <sup>TM</sup>	ISOPLANAR <sup>TM</sup>	SuperSOT <sup>TM</sup> -3	
E <sup>2</sup> CMOS <sup>TM</sup>	MICROWIRE <sup>TM</sup>	SuperSOT <sup>TM</sup> -6	
EnSigna <sup>TM</sup>	OPTOLOGIC <sup>TM</sup>	SuperSOT <sup>TM</sup> -8	
FACT <sup>TM</sup>	OPTOPLANAR <sup>TM</sup>	SyncFET <sup>TM</sup>	
FACT Quiet Series <sup>TM</sup>	POP <sup>TM</sup>	TinyLogic <sup>TM</sup>	
FAST <sup>®</sup>	PowerTrench <sup>®</sup>	UHC <sup>TM</sup>	

## DISCLAIMER

FAIRCHILD SEMICONDUCTOR RESERVES THE RIGHT TO MAKE CHANGES WITHOUT FURTHER NOTICE TO ANY PRODUCTS HEREIN TO IMPROVE RELIABILITY, FUNCTION OR DESIGN. FAIRCHILD DOES NOT ASSUME ANY LIABILITY ARISING OUT OF THE APPLICATION OR USE OF ANY PRODUCT OR CIRCUIT DESCRIBED HEREIN; NEITHER DOES IT CONVEY ANY LICENSE UNDER ITS PATENT RIGHTS, NOR THE RIGHTS OF OTHERS.

## LIFE SUPPORT POLICY

FAIRCHILD'S PRODUCTS ARE NOT AUTHORIZED FOR USE AS CRITICAL COMPONENTS IN LIFE SUPPORT DEVICES OR SYSTEMS WITHOUT THE EXPRESS WRITTEN APPROVAL OF FAIRCHILD SEMICONDUCTOR CORPORATION. As used herein:

1. Life support devices or systems are devices or systems which, (a) are intended for surgical implant into the body, or (b) support or sustain life, or (c) whose failure to perform when properly used in accordance with instructions for use provided in the labeling, can be reasonably expected to result in significant injury to the user.
2. A critical component is any component of a life support device or system whose failure to perform can be reasonably expected to cause the failure of the life support device or system, or to affect its safety or effectiveness.

## PRODUCT STATUS DEFINITIONS

### Definition of Terms

Datasheet Identification	Product Status	Definition
Advance Information	Formative or In Design	This datasheet contains the design specifications for product development. Specifications may change in any manner without notice.
Preliminary	First Production	This datasheet contains preliminary data, and supplementary data will be published at a later date. Fairchild Semiconductor reserves the right to make changes at any time without notice in order to improve design.
No Identification Needed	Full Production	This datasheet contains final specifications. Fairchild Semiconductor reserves the right to make changes at any time without notice in order to improve design.
Obsolete	Not In Production	This datasheet contains specifications on a product that has been discontinued by Fairchild semiconductor. The datasheet is printed for reference information only.